

*ROTATING RIGHT*

# **SEEPEX GROUP CS PROGRESSIVE CAVITY PUMPS**

Product group CS.

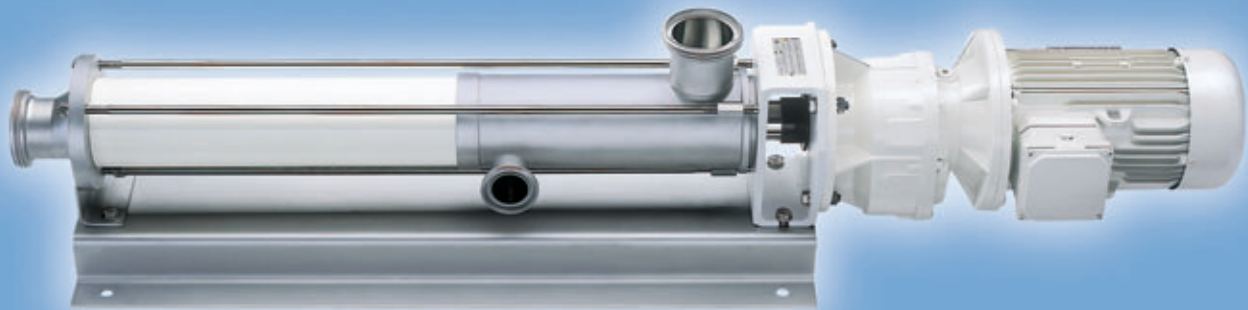

# CS – Food grade pumps

The 3 product ranges of the CS product group are used primarily in the food, pharmaceutical, cosmetics and chemical industries. "C" stands for CIP (Cleaning in Place) and "S" for SIP-capability (Sterilisation In Place) of the pumps. CS pumps satisfy the highest requirements with regard to gentle conveying, sanitation, cleaning and sterilisation. They are certified acc. to the 3-A Sanitary Standard of the US and designed in compliance with the EHEDG directives.

## Coupling rod

made of stainless steel for power transmission, available with propellers or feed screw.

## Stator

in standard design or with even wall thickness. The seal on both ends is moulded as an integral part of the elastomeric stator; corrosion of the stator tube is never a problem because the pumped liquid never comes into contact with the metal tube or the bonding adhesive.

## Rotor

wear resistant and corrosion-proof materials. Alternatively with additional surface treatment.

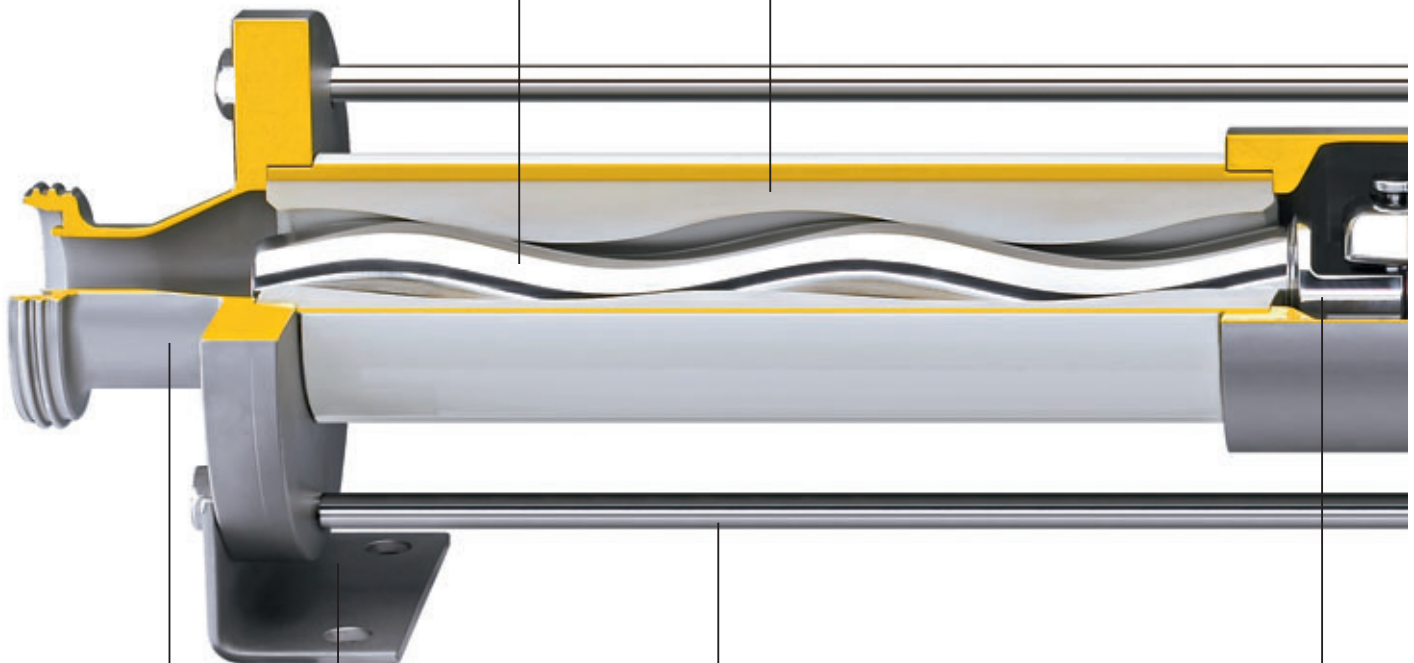

## Support

made of stainless steel, satin finish for superior resistance to corrosive cleaning and sanitizing chemicals.

## Open fork joint

for transmission of power, BCSO model designed as an open "hygienic joint" for optimum cleaning as well as highest resistance to corrosion and wear. Service-friendly due to assembly without special tools. Range BCSB designed with closed pin joint.

## Open pin joint

newly developed hygienic joint, designed for higher pressures and flow rates.

(see detail)

## Pressure branch

made of stainless steel, with internally polished finish and externally satin finish. Designed with almost no "dead zones" and features to allow complete draining. Standard connection to DIN 11851, 11864 or Tri Clamp® alternatives.

## Tie bolts

and all other fittings are corrosion proof.

**Mechanical seal**  
flushed by the product and located inside  
the suction area for optimal cleaning.

**Mechanical seal housing**  
made of stainless steel for  
mounting the mechanical seal,  
available with quench.

**Drive**  
geared motors, variable speed drives or  
frequency controlled drives, directly  
flanged to the pump without additional  
coupling. Upon request with cover  
made of stainless steel.

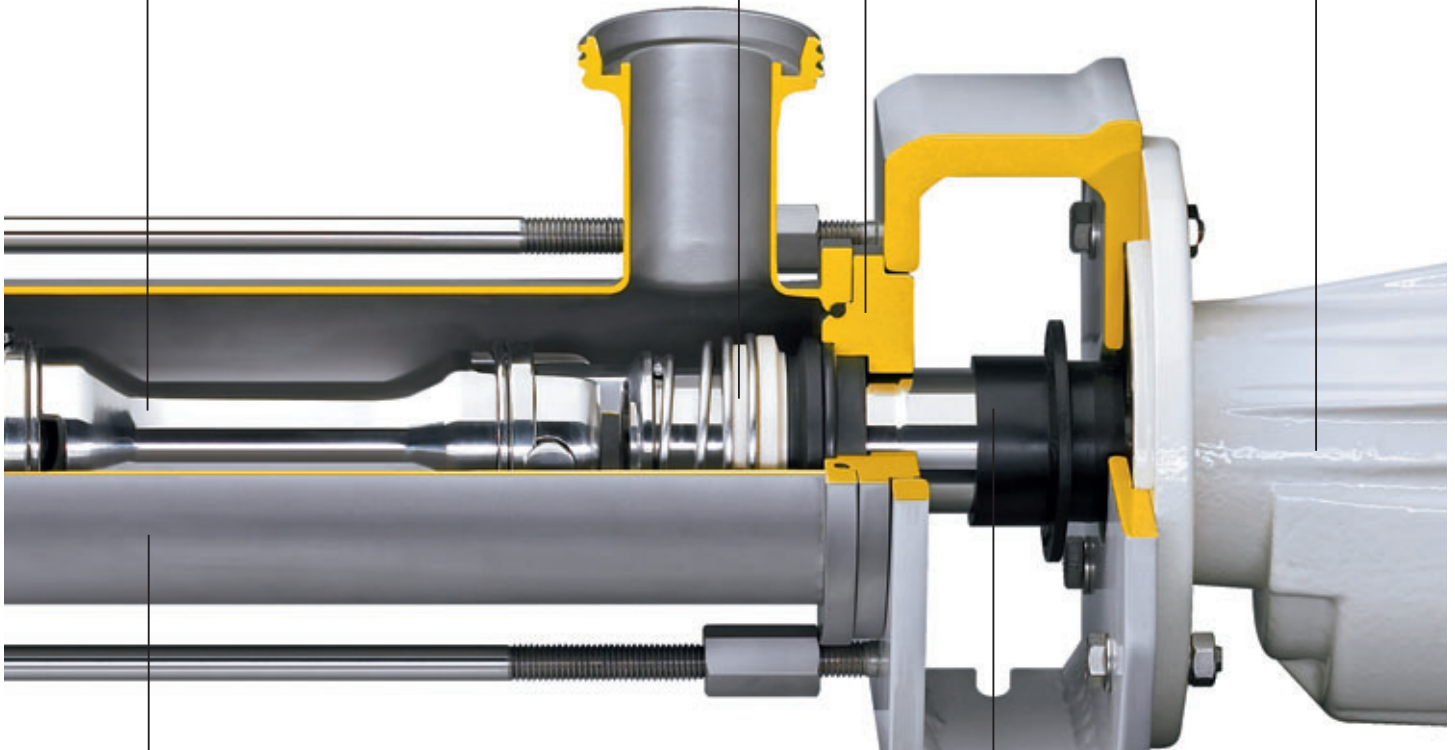

**Plug-in shaft connection**  
for easy dismantling of the pump and drive  
enabling quick replacement of the rotating  
parts and shaft seals. The plug-in shaft pin  
secures the shaft connection to the drive  
and the splash ring protects the bearing  
from contamination/gland leakage.

**Plug-in shaft**  
made of stainless steel. Open design  
for easy CIP and designed to mount the  
mechanical seal.

**Lantern**  
in corrosion resistant design, optio-  
nally made of stainless steel, for  
connection of pump and drive and  
to secure the assembly to the base-  
plate or skid.

**Suction casing**  
made of stainless steel, internally polished external satin  
finish. Almost "Dead zone free" design with suction connec-  
tion above the mechanical seal enables CIP solutions to  
flow through the entire casing. Choice of off-set CIP-  
connection for almost residue-free cleaning and complete  
draining. Options with jackets for heating. Standard connec-  
tions according to DIN 11851, 11864 or Tri Clamp®.

**Detail: Open pin joint**



# Why food grade pumps?

Because they are used in applications such as agriculture, brewing industry and distilleries, chemical and biochemical industry, confectionery industry, dough processing and bakeries, fruit and vegetable processing, milk and dairy industry, pharmaceutical and cosmetics industry, poultry and meat processing and wine industry.

## Features

- Gentle handling of flowable and high viscosity products with controllable flows and pressures
  - Easy cleaning: optimised pump casing designs with minimal residual volume that provide simple CIP operations
  - Service-friendly with easily disassembled universal joints
  - Sanitary mechanical seals selected for the respective application
  - Stator materials and secondary seals with FDA approval available
  - SIP with steam is an available option with cycled operation of the pump
- > Conveying capacity: 30 l/h–130 m<sup>3</sup>/h (0.13 GPM–575 GPM),  
Pressure: up to 24 bar (360 psi)

# Overview of ranges

The pumps of the BCSO range are equipped with open hygienic joints that can be cleaned without leaving residues through CIP continuous cleaning. They meet highest demands on hygienic cleanliness and on corrosion and wear resistance. The open fork joint features an especially shaped coupling rod and the rotor or plug-in shaft head. Apart from that, it is made up of only a few components. For higher pressures and conveying capacities, seepex additionally offers a newly developed, open pin joint. Service work can be performed easily and rapidly without the need for special tools. They are certified acc. to the 3-A Sanitary Standard of the US and designed in compliance with the EHEDG directives.

The pumps of the BCSB range differ from those of range BCSO in their joint design. The BCSB range is equipped with the proven, closed pin joints from the seepex pumps of the BN/NS ranges. These cost-efficient and wear-resistant pin joints are filled with a special grease approved for the food sector and sealed through a resilient universal joint sleeve and holding bands. They are suited for use with abrasive conveying media and high operating pressures.

The BTCS range features a feed hopper with a cylindrical/conical compression zone. Highly-viscous conveying media with a low degree of flowability are fed to the conveying elements rotor and stator through the auger feed screw on the coupling rod. Optimum filling of the conveying chamber is achieved through the priming pressure generated in the compression zone. The pumps of the BTCS range are optionally equipped with the open, service-friendly joints or with the proven, closed pin joints.

## Range BCSO

---

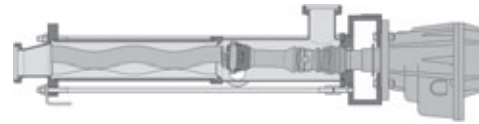

## Range BCSB

---

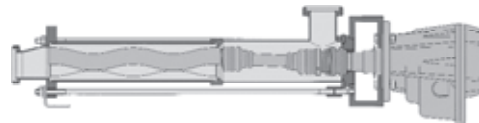

## Range BTCS

---

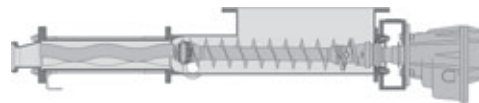

# User Advantages

## Rotor - Stator-Geometries

### seepex 6L - conventional geometry comparison

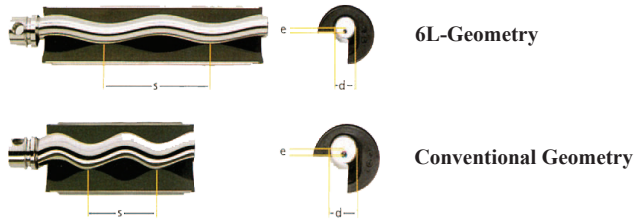

smaller rotor diameter  
 + reduced eccentricity  
 + increased pitch length  
 = 6L-Geometry with 20 % lower sliding velocity

- Improved service life (+35-50%) due to lower sliding velocity and longer sealing line
- Better pressure stability due to wider sealing line
- Reduced thrust loads on universal joints and bearings due to smaller rotor diameter and lower eccentricity
- Thrust loads of the conventional design exceed the thrust loads of the 6L-Geometry by approx. 50 %
- Smooth and almost pulsation-free operation
- The "stretched cavities" have a positive influence on vibrations, turbulences, pulsation and shear rates

## seepex Universal Joint Design

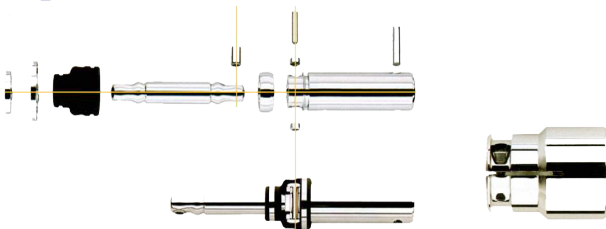

### Benefits

- Only 4 hardened and wear resistant universal joint components (1 coupling rod bush, 2 guide bushes, 1 coupling rod pin)
- Positively sealed, gas and liquid tight elastomer universal joint sleeve
- Optional stainless steel universal joint sleeve protector with unconditioned - 10.000 h/24 months guarantee on the protected universal joint
- Simple and cost-effective to maintain
- Streamlined design, thus improved NPSH conditions
- Simple and cost-effective to maintain

## seepex has The Optimum Rotor Surface

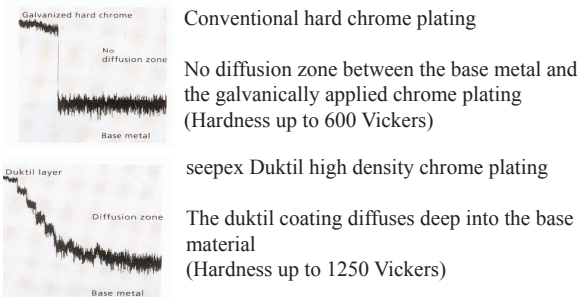

Conventional hard chrome plating

No diffusion zone between the base metal and the galvanically applied chrome plating (Hardness up to 600 Vickers)

seepex Duktal high density chrome plating

The duktil coating diffuses deep into the base material (Hardness up to 1250 Vickers)

### Benefits of the high quality seepex rotor surface

- Reduced starting and operating torque
- Improved efficiencies
- Smoother operations
- Increased service life
- The hardness of the coating is 1250 Vickers versus 180 of the base material
- The adhesion to the base material is excellent with no surface fissures

## seepex Molded to size stators



seepex molded to size stators are shrink compensated and have cast-on sealing surfaces.

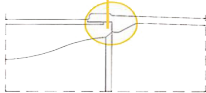

High manufacturing standards guarantee low torque requirements and high efficiencies.

A wide variety of elastomers is available.

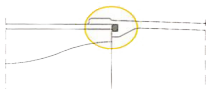

Cut-to-size stators with separate gaskets or joints - unthinkable for seepex

## seepex Optional TSE Dry Run Protection

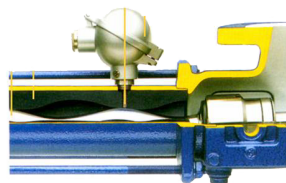

### Benefits

- Universal solution for all applications protects pump and stator against damages caused by frictional heat due to lack of liquid pumped
- Highly efficient low cost dry running protection system



TSE controller for panel mounting



Complete IP55 (NEMA 4) pump control panel with incorporated TSE controller

ROTATING RIGHT

**Head Office:**  
 6120 Davies Road  
 Edmonton, AB  
 T6E 4M9

Phone: (780) 485-2010 • Toll Free: (866) 707-7867  
 Fax: (780) 485-1938  
 • Calgary • Drayton Valley • Lethbridge  
[www.rotatingright.com](http://www.rotatingright.com)